

HOLUX GR-213

GPS Receiver

User's Guide

HOLUX Technology, Inc

No. 1-1, Innovation Road 1, Science-Based Industrial Park, Hsinchu Taiwan

Phone: +886-3-6687000 Fax: +886-3-6687111

E-Mail: info@holux.com.tw Web: www.holux.com.tw

All Right Reserved

TABLE OF CONTENTS

1. Introduction	3
1.1 Overview	3
1.2 Features	3
1.3 Technology specifications	3
1.3.1 Physical Dimension.....	3
1.3.2 Environmental Characteristics.....	3
1.3.3 Electrical Characteristics.....	3
1.3.4 Performance	3
2. Operational characteristics	4
2.1 Initialization.....	4
2.2 Navigation	4
3. Hardware interface	5
3.1 Dimension	5
3.2 Hardware Interface	5
3.3 Connector	5
3.3.1 Function definition of PS-2 female composite connectors.....	6
3.4 Accessories.....	6
3.5 Optional Cigarette Adapter.....	7
4. USB Driver	7
4.1 System Requirements	7
4.2 Installation.....	7
4.3 Important	8
5. Software Interface	8
5.1 NMEA Transmitted Messages.....	8
NMEA Record	8
5.1.1 Global Positioning System Fix Data (GGA).....	8
5.1.2 Geographic Position with Latitude/Longitude(GLL).....	9
5.1.3 GNSS DOP and Active Satellites (GSA)	9
5.1.4 GNSS Satellites in View (GSV).....	10
5.1.5 Recommended Minimum Specific GNSS Data (RMC)	10
5.1.6 Course Over Ground and Ground Speed (VTG)	11
6. Earth Datums.....	12
6.2.1 Manufacturing Default:	13
6.2.2 Datum change syntax:	13
7. Ordering Information	14
Explanation of product Number.....	14
8. Warranty.....	14

1. Introduction

1.1 Overview

The HOLUX **GR-213 Smart GPS Receiver** is a total solution GPS receiver, designed based on SiRF Star III Architecture. This positioning application meets strict needs such as car navigation, mapping, surveying, security, agriculture and so on. Only clear view of sky and certain power supply are necessary to the unit. It communicates with other electronic utilities via compatible dual-channel through RS-232 or TTL and saves critical satellite data by built-in backup memory. With low power consumption, the **GR-213** tracks up to 20 satellites at a time, re-acquires satellite signals in 100 ms and updates position data every second. Trickle-Power allows the unit operates a fraction of the time and Push-to-Fix permits user to have a quick position fix even though the receiver usually stays off.

1.2 Features

The GR-213 provides a host of features that make it easy for integration and use.

1. SiRFstarIII chipset with embedded ARM7TDMI CPU available for customized applications in firmware.
2. High performance receiver tracks up to 20 satellites while providing first fast fix and low power consumption.
3. Differential capability utilizes real-time RTCM corrections producing 1-5 meter position accuracy.
4. Compact design ideal for applications with minimal space.
5. A rechargeable battery sustains internal clock and memory. The battery is recharged during normal operation.
6. User initialization is not required.
7. Dual communication channels and user selectable baud rates allow maximum interface capability and flexibility.
8. Optional communication levels, RS-232 and TTL meet ordinary application and new fashions of connecting PDA with TTL or RS-232 output.
9. FLASH based program memory: New software revisions upgradeable through serial interface.
10. LED display status: The LED provides users visible positioning status. LED "ON" when power connected and "BLINKING" when GR-213 got positioned.
11. Built-in WAAS Demodulator.
12. Water proof design for industry standard.

1.3 Technology specifications

1.3.1 Physical Dimension

Single construction integrated antenna/receiver.

Size: 64.5 x 42 x 17.8 (mm)
2.54" x 1.65 x 0.7 (Inch).

1.3.2 Environmental Characteristics

- 1) Operating temperature: -10°C to +60°C (internal temperature).
- 2) Storage temperature: -20°C to +70°C.

1.3.3 Electrical Characteristics

- 1) Input voltage: +4.5 ~ 5.5 VDC without accessories.
- 2) Backup power: 3V Rechargeable Lithium cell battery, up to 500 hours discharge.

1.3.4 Performance

- 1) Tracks up to 20 satellites.
- 2) Update rate: 1 second.
- 3) Acquisition time
 - Reacquisition 0.1 sec., averaged
 - Hot start 1 sec., averaged
 - Warm start 38 sec., averaged

- Cold start 42 sec., averaged
- 4) Position accuracy:
- A) Non DGPS (Differential GPS)
- | | |
|----------|-------------------------------------|
| Position | 5-25 meter CEP without SA |
| Velocity | 0.1 meters/second, without SA |
| Time | 1 microsecond synchronized GPS time |
- B) DGPS (Differential GPS)
- | | |
|----------|-----------------------------|
| Position | 1 to 5 meter, typical |
| Velocity | 0.05 meters/second, typical |
- C) EGNOS/WAAS/Beacon
- | | |
|----------|--|
| Position | < 2.2 meters, horizontal 95% of time
< 5 meters, vertical 95% of time |
|----------|--|
- 5) Dynamic Conditions:
- | | |
|--------------|-------------------------------------|
| Altitude | 18,000 meters (60,000 feet) max |
| Velocity | 515 meters / second (700 knots) max |
| Acceleration | 4 G, max |
| Jerk | 20 meters/second, max |

1.3.5 Interfaces

- 1) Dual channel RS-232 or TTL compatible level, with user selectable baud rate (4800-Default, 9600, 19200, 38400).
- 2) NMEA 0183 Version 2.2 ASCII output (GGA, GSA, GSV, RMC, option GLL, VTG, ZDA).
- 3) Real-time Differential Correction input (RTCM SC-104 message types 1,2 and 9).
- 4) SiRF binary protocol.

2. Operational characteristics

2.1 Initialization

As soon as the initial self-test is complete, the GR-213 begins the process of satellite acquisition and tracking automatically. Under normal circumstances, it takes approximately 42 seconds to achieve a position fix, 38 seconds if ephemeris data is known. After a position fix has been calculated, information about valid position, velocity and time is transmitted over the output channel.

The GR-213 utilizes initial data, such as last stored position, date, time and satellite orbital data, to achieve maximum acquisition performance. If significant inaccuracy exists in the initial data, or the orbital data is obsolete, it may take more time to achieve a navigation solution. The GR-213 Auto-locate feature is capable of automatically determining a navigation solution without intervention from the host system. However, acquisition performance can be improved as the host system initializes the GR-213 in the following situation:

- 1) Moving further than 500 kilometers.
- 2) Failure of data storage due to the inactive internal memory battery.

2.2 Navigation

After the acquisition process is complete, the GR-213 sends valid navigation information over output channels. These data include:

- 1) Latitude/longitude/altitude
- 2) Velocity
- 3) Date/time
- 4) Error estimates
- 5) Satellite and receiver status

The GR-213 sets the default of auto-searching for real-time differential corrections in RTCM SC-104 standard format, with the message types 1, 5, or 9. It accomplishes the satellite data to generate a differential (DGPS) solution. The host system, at its option, may also command the GR-213 to output a position whenever a differential solution is available.

3. Hardware interface

3.1 Dimension

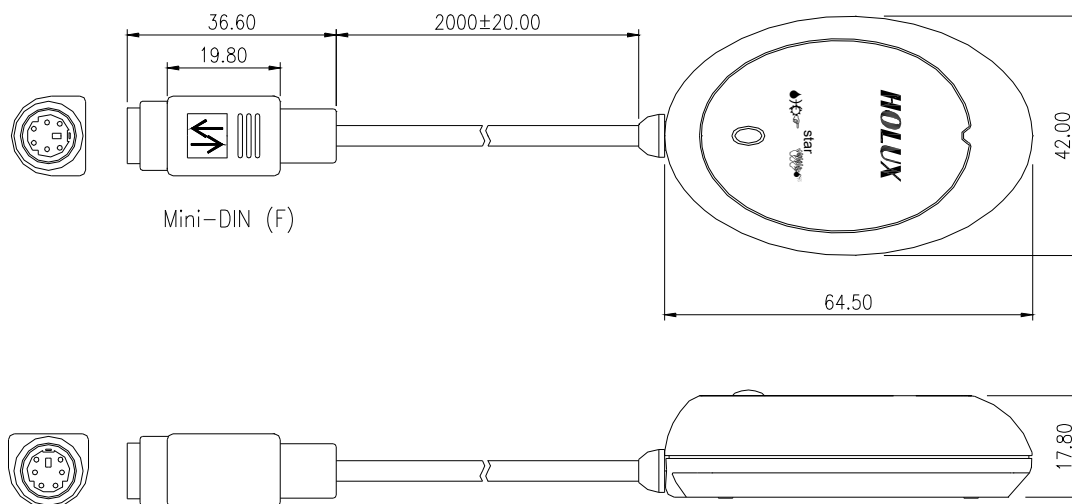

3.2 Hardware Interface

The GR-213 includes an antenna in a unique style waterproof gadget. Simply connect PS-2 female connector to one of the accessories linking to your notebook PC, PDA or other devices. The one-piece cigarette adapter allows you to connect GR-213 to your PDAs. Optional color, input voltage and output connector are listed and described below:

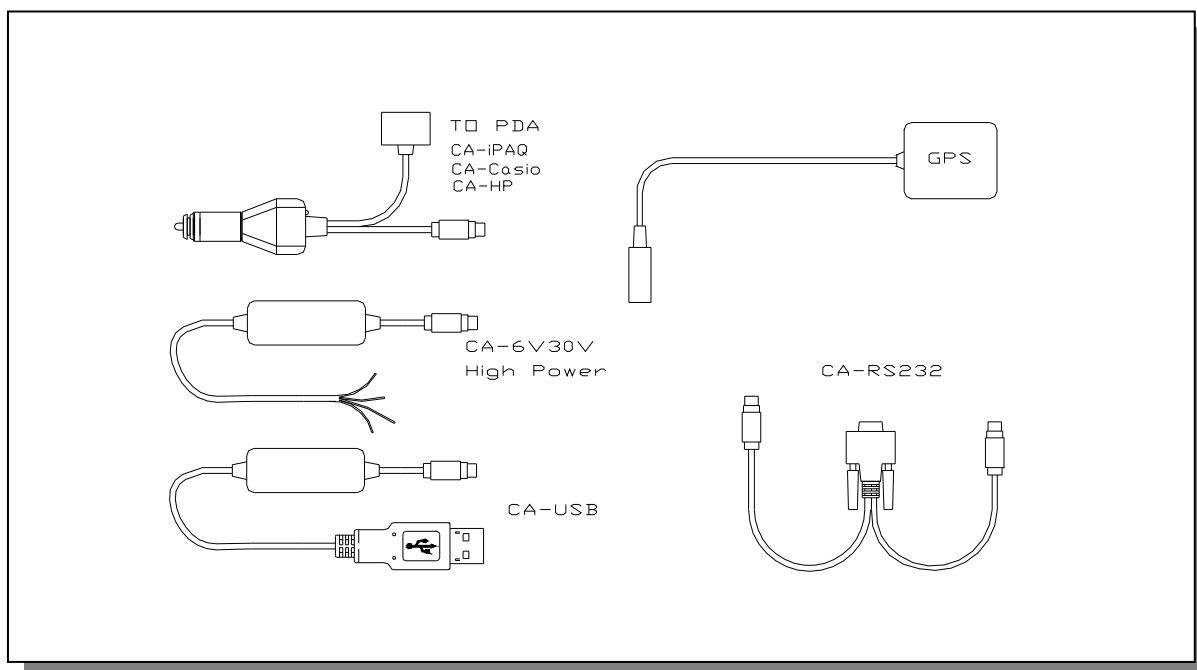

3.3 Connector

The GR-213 is equipped with optional connectors.

Cable Length: 2 meter

3.3.1 Function definition of PS-2 female composite connectors

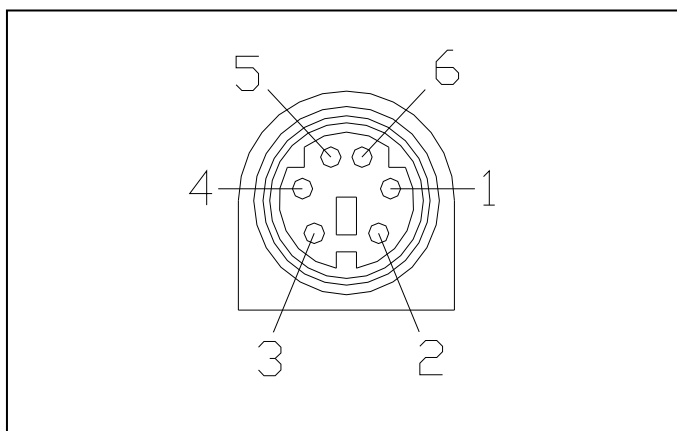

Pin	Signal	
	RS-232	RS232+TTL
1	Tx	TX(RS232)
2	+5VDC	+5VDC
3	NC	Tx(TTL)
4	Ground	Ground
5	DGPS IN	Rx(TTL)
6	Rx	RX(RS232)

N. C. = No Connection

3.4 Accessories

3.4.1 CA-RS232: DB 9 pins Female and PS-2 male connector:

Cable Length: To GR-213: 1 meter

RS-232 to PS-2: 45 cm

3.4.1.1 DB 9 pins Female connector function definition:

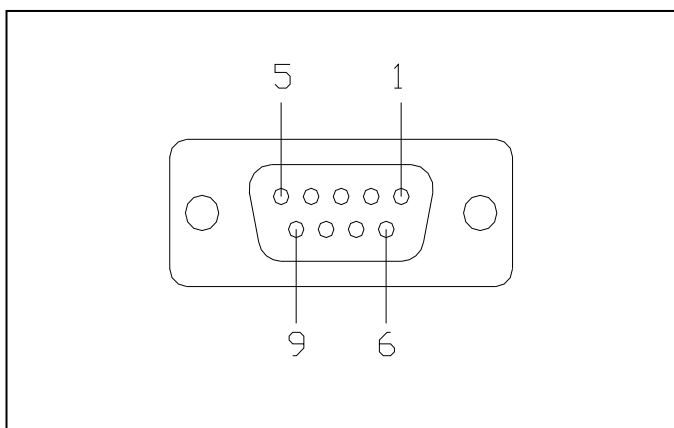

Pin	Signal Name
1	N.C
2	Tx
3	Rx
4	N.C
5	接地
6	N.C
7	N.C
8	N.C
9	DGPS in

N.C = No connection

3.4.1.2 PS2 composite connector function definition:

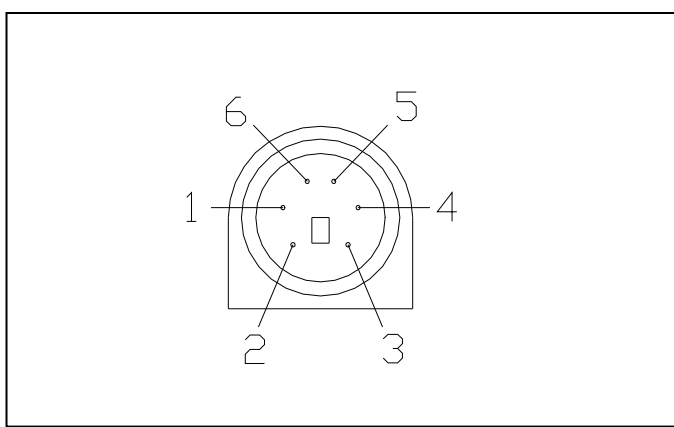

Pin	Signal Name
1	+5V
2	N.C
3	N.C
4	Ground
5	N.C
6	N.C

N.C = No connection

3.4.2 Cigarette adapter and PDA connector:

reference section 7.2

3.4.3 CA-USB: USB connector

The USB A Type is equipped with GR-213. The function definition is as follows:

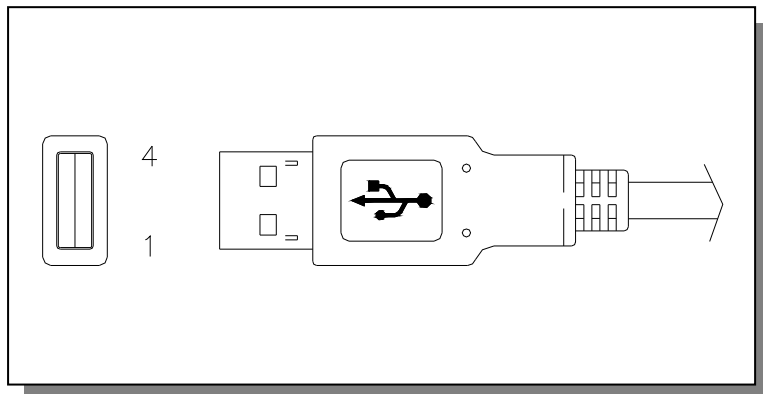

Pin	Signal Name
1	+5V
2	D +
3	D -
4	Ground

3.4.4 CA-6V30V: High power connector

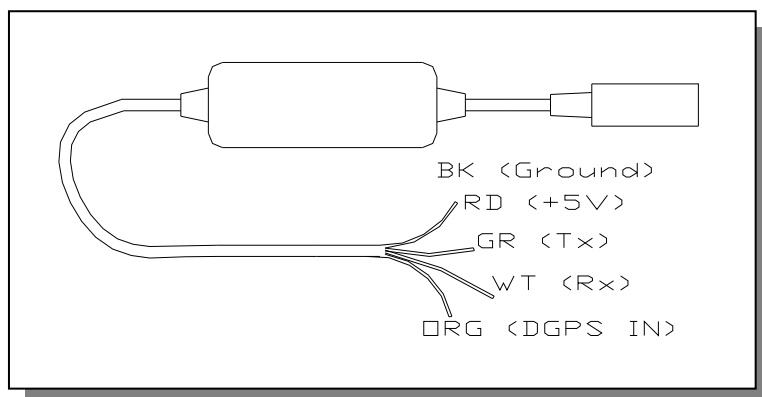

Color	Signal
Black	Ground
Red	+6~30VDC
Green	Tx
White	Rx
Orange	DGPS IN

3.5 Optional Cigarette Adapter

The optional cigarette adapter is with 2-meter cable for using in a car or boat.
Input voltage: DC12V - 26V

4. USB Driver

4.1 System Requirements

IBM, Pentium or above and other compatible PC; 16 MB and above memory; Windows 98/Me/2000; VGA Graphic Adapter.

4.2 Installation

1. Copy entire <GR-213 USB> folder from CD to hard disk.
2. Connect GR-213 USB connector to computer. While the computer automatically starts the installation program, please direct the driver to the <GR-213 USB> folder.

3. After the installation is complete, go to <Device Manager> and select <Ports (COM & LPT)> to verify if a virtual COM port <USB to Serial Port> was created.

4.3 Important

Verify the COM port # to start using your own navigating software.

1. Click <Start> menu, select <Settings>, then enter <Control Panel>.
2. After entering <Control Panel>, select <System>.
3. Select <Device Manager>.
4. Find the <Connect port> and check the Virtual COM Port, which was created by the USB driver, Please note that the Virtual COM Port number might be different from every computer. Before using navigating software, please confirm the COM Port numbers created by your computer and provided by your navigation software. Otherwise, the navigating software won't receive the satellite signal, because of the un-match COM Port setting.

5. Software Interface

The GR-213 interface protocol is based on the National Marine Electronics Association's NMEA 0183 ASC II interface specification, which is defined in NMEA 0183, Version 2.2 and the Radio Technical Commission for Maritime Services (RTCM Recommended Standards For Differential Navstar GPS Service, Version 2.1, RTCM Special Committee No.104, Type 1,2,9) or **WAAS** (in **USA area**) or **EGNOS** (in **European area**).

5.1 NMEA Transmitted Messages

The GR-213 supported by SiRF Technology Inc. also outputs data in NMEA-0183 format as defined by the National Marine Electronics Association (NMEA), Standard.

The default communication parameters for NMEA output are 4800 baud, 8 data bits, stop bit, and no parity.

Table 5-1 NMEA-0183 Output Messages

NMEA Record	Description
GPGGA	Global positioning system fixed data
GPGLL	Geographic position- latitude/longitude
GPGSA	GNSS DOP and active satellites
GPGSV	GNSS satellites in view
GPRMC	Recommended minimum specific GNSS data
GPVTG	Course over ground and ground speed

5.1.1 Global Positioning System Fix Data (GGA)

Table 5-2 contains the values for the following example:

\$GPGGA,161229.487,3723.2475,N,12158.3416,W,1,07,1.0,9.0,M, , , ,0000*18

Table 5-2 GGA Data Format

Name	Example	Units	Description
Message ID	\$GPGGA		GGA protocol header
UTC Time	161229.487		hhmmss.sss
Latitude	3723.2475		ddmm.mmmm
N/S Indicator	N		N=north or S=south
Longitude	12158.3416		dddmm.mmmm
E/W Indicator	W		E=east or W=west
Position Fix Indicator	1		See Table 5-3
Satellites Used	07		Range 0 to 20
HDOP	1.0		Horizontal Dilution of Precision

MSL Altitude	9.0	Meters	
Units	M	Meters	
Geoid Separation		Meters	
Units	M	Meters	
Age of Diff. Corr.		second	Null fields when DGPS is not used
Diff. Ref. Station ID	0000		
Checksum	*18		
<CR> <LF>			End of message termination

Table 5-3 Position Fix Indicator

Value	Description
0	0 Fix not available or invalid
1	GPS SPS Mode, fix valid
2	Differential GPS, SPS Mode, fix valid
3	GPS PPS Mode, fix valid

5.1.2 Geographic Position with Latitude/Longitude(GLL)

Table 5-4 contains the values for the following example:

\$GPGLL,3723.2475,N,12158.3416,W,161229.487,A*2C

Table 5-4 GLL Data Format

Name	Example	Units	Description
Message ID	\$GPGLL		GLL protocol header
Latitude	3723.2475		ddmm.mmmm
N/S Indicator	N		N/S Indicator N N=north or S=south
Longitude	12158.3416		dddmm.mmmm
E/W Indicator	W		E=east or W=west
UTC Position	161229.487		hhmmss.sss
Status	A		A=data valid or V=data not valid
Checksum	*2C		
<CR> <LF>			End of message termination

5.1.3 GNSS DOP and Active Satellites (GSA)

Table 5-5 contains the values for the following example:

\$GPGSA,A,3,07,02,26,27,09,04,15,, , , , ,1.8,1.0,1.5*33

Table 5-5 GSA Data Format

Name	Example	Units	Description
Message ID	\$GPGSA		GSA protocol header
Mode 1	A		See Table 5-6
Mode 2	3		See Table 5-7
Satellite Used(1)	07		Sv on Channel 1
Satellite Used(1)	02		Sv on Channel 2
.....		
Satellite Used			Sv on Channel 20
PDOP	1.8		Position Dilution of Precision
HDOP	1.0		Horizontal Dilution of Precision
VDOP	1.5		Vertical Dilution of Precision
Checksum	*33		
<CR> <LF>			End of message termination

1. Satellite used in solution.

Table 5-6 Mode 1

Value	Description
M	Manual—forced to operate in 2D or 3D mode
A	2DAutomatic—allowed to automatically switch 2D/3D

Table 5-7 Mode 2

Value	Description
1	Fix Not Available
2	2D
3	3D

5.1.4 GNSS Satellites in View (GSV)

Table 5-8 contains the values for the following example:

```
$GPGSV,2,1,07,07,79,048,42,02,51,062,43,26,36,256,42,27,27,138,42*71
$GPGSV,2,2,07,09,23,313,42,04,19,159,41,15,12,041,42*41
```

Table 5-8 GSV Data Format

Name	Example	Units	Description
Message ID	\$GPGSV		GSV protocol header
Number of Messages	2		Range 1 to 3
Message Number	1		Range 1 to 3
Satellites in View	07		Range 1 to 12
Satellite ID	07		Channel 1 (Range 1 to 32)
Elevation	79	degrees	Channel 1 (Maximum 90)
Azimuth	048	degrees	Channel 1 (True, Range 0 to 359)
SNR (C/No)	42	dBHz	Range 0 to 99, null when not tracking
....		
Satellite ID	27		Channel 4 (Range 1 to 32)
Elevation	27	degrees	Channel 4 (Maximum 90)
Azimuth	138	degrees	Channel 4 (True, Range 0 to 359)
SNR (C/No)	42	dBHz	Range 0 to 99, null when not tracking
Checksum	*71		
<CR> <LF>			End of message termination

NOTE: Items <4>,<5>,<6> and <7> repeat for each satellite in view to a maximum of four (4) satellites per sentence. Additional satellites in view information must be sent in subsequent sentences. These fields will be null if unused.

5.1.5 Recommended Minimum Specific GNSS Data (RMC)

Table 5-9 contains the values for the following example:

```
$GPRMC,161229.487,A,3723.2475,N,12158.3416,W,0.13,309.62,120598, ,*10
```

Table 5-9 RMC Data Format

Name	Example	Units	Description
Message ID	\$GPRMC		RMC protocol header
UTC Time	161229.487		hhmmss.sss

Status	A		A=data valid or V=data not valid
Latitude	3723.2475		ddmm.mmmm
N/S Indicator	N		N=north or S=south
Longitude	12158.3416		dddmm.mmmm
E/W Indicator	W		E=east or W=west
Speed Over Ground	0.13	knots	
Course Over Ground	309.62	degrees	True
Date	120598		ddmmyy
Magnetic Variation(1)		degrees	E=east or W=west
Checksum	*10		
<CR> <LF>			End of message termination

1. SiRF Technology Inc. does not support magnetic declination. All "course over ground" data are geodetic WGS84 directions.

5.1.6 Course Over Ground and Ground Speed (VTG)

Table 5-10 contains the values for the following example:

\$GPVTG,309.62,T, ,M,0.13,N,0.2,K*6E

Table 5-10 VTG Data Format

Name	Example	Units	Description
Message ID	\$GPVTG		VTG protocol header
Course	309.62	degrees	Measured heading
Reference	T		True
Course		degrees	Measured heading
Reference	M		Magnetic(1)
Speed	0.13	knots	Measured horizontal speed
Units	N		Knots
Speed	0.2	km/hr	Measured horizontal speed
Units	K		Kilometers per hour
Checksum	*6E		
<CR> <LF>			End of message termination

1. SiRF Technology Inc. does not support magnetic declination. All "course over ground" data are geodetic WGS84 directions.

5.1.7 ZDA—SiRF Timing Message

Outputs the time associated with the current 1 PPS pulse. Each message will be output within a few hundred ms after the 1 PPS pulse is output and will tell the time of the pulse that just occurred.

Table 5-11 contains the values for the following example:

\$GPZDA,181813,14,10,2003,00,00*4F

Table 5-11 ZDA Data Format

Name	Example	Units	Description
Message ID	\$GPZDA		ZDA protocol header
UTC Time	181813		Either using valid IONO/UTC or estimated from default leap seconds
Day	14		01 TO 31
Month	10		01 TO 12
Year	2003		1980 to 2079
Local zone hour	00	knots	Offset from UTC (set to 00)
Local zone hour	00		Offset from UTC (set to 00)
Checksum	4F		
<CR> <LF>			End of message termination

5.2 RTCM Received Data

The default communication parameters for DGPS Input are 9600 baud, 8 data bits, stop bit, and no parity. Position accuracy of less than 5 meters can be achieved with the GR-213 by using Differential GPS (DGPS) real-time pseudo-range correction data in RTCM SC-104 format, with message types 1,2, or 9. As using DGPS receiver with different communication parameters, GR-213 may decode the data correctly to generate accurate messages and save them in battery-back SRAM for later computing.

6. Earth Datums

6.1 Earth Datums

The following is a list of the GR-213 earth datum index and the corresponding earth datum name:

Item	Datum	Reference Ellipsoid	Data name
1	Adindan - Ethiopia	Clarke 1880	Data1.dat
2	Afgooye – Somalia	Krassovsky	Data2.dat
3	Alaska, Conus – North American 1983	GRS 1980	Data3.dat
4	Albania – S-42 (Pulkovo 1942)	Krassovsky 1940	Data63.dat
5	Argentina	South American 1969	Data4.dat
6	Australia	Australian – National	Data70.dat
7	Bahrain – Ain el ABD 1970	International	Data5.dat
8	Bangladesh	Everest 1830	Data6.dat
9	Bolivia	South American 1969	Data8.dat
10	Botswana – ARC 1950	Clarke 1880	Data7.dat
11	Brazil	South American 1969	Data9.dat
12	Brunel, East Malaysia	Everest (Sabah & Sarawak)	Data37.dat
13	Canada – North American 1983	GRS 1980	Data10.dat
14	Chile	South American 1969	Data13.dat
15	Colombia	South American 1969	Data12.dat
16	Colombia – Provisional American 1956	International	Data11.dat
17	Czechoslovakia – S-42 (Pulkovo 1942)	Krassovsky 1940	Data64.dat
18	Ecuador	South American 1969	Data14.dat
19	European 1950 – Central Regional Mean	International	Data29.dat
20	European 1950 – Cyprus	International	Data15.dat
21	European 1950 – Eastern Regional Mean	International	Data16.dat
22	European 1950 – Egypt	International	Data17.dat
23	European 1950 – Finland, Norway	International	Data18.dat
24	European 1950 – Greece	International	Data19.dat
25	European 1950 – Iran	International	Data20.dat
26	European 1950 – Italy (Sardinia)	International	Data21.dat
27	European 1950 – Italy (Sicily)	International	Data22.dat
28	European 1950 – Malta	International	Data23.dat
29	European 1950 – Northern Regional Mean	International	Data24.dat
30	European 1950 – Portugal, Spain	International	Data25.dat
31	European 1950 – Southern Regional Mean	International	Data26.dat
32	European 1950 – Tunisia	International	Data27.dat
33	European 1950 – Western Regional mean	International	Data28.dat
34	Guyana - South American 1969	South American 1969	Data30.dat
35	Hawaii-North American 1983	GRS1980	Data32.dat
36	Hong Kong	International	Data31.dat
37	Hu_Tsu_Shan Taiwan	International	Data33.dat
38	Hungary – S-42 (Pulkovo 1942)	Krassovsky 1940	Data65.dat
39	Indian 1960	Everest 1830	Data34.dat
40	Ireland - 1965	Modified Airy	Data35.dat
41	Kazakhstan – S-42 (Pulkovo 1942)	Krassovsky 1940	Data65.dat

42	Kenya, Tanzania- ARC 1960	Clarke 1880	Data53.dat
43	Latvia – S-42 (Pulkovo 1942)	Krassovsky 1940	Data67.dat
44	Liberia – 1964	Clarke 1880	Data36.dat
45	Mexico, central America	GRS1980	Data38.dat
46	OMAN	Clarke 1880	Data39.dat
47	Pakistan	Everest 1830	Data40.dat
48	Paraguay - South American 1969	South American 1969	Data42.dat
49	Peru1 – South American 1969	South American 1969	Data41.dat
50	Philippines	Clarke 1866	Data43.dat
51	Poland – S-42 (Pulkovo 1942)	Krassovsky 1940	Data68.dat
52	Potsdam	Bessel 1841	Data71.dat
53	Puerto Rico – Virgin Islands	Clarke 1866	Data44.dat
54	Qatar national	International	Data45.dat
55	Qornoq – Greenland (SOUTH)	International	Data46.dat
56	Regional Mean	South American 1969	Data48.dat
57	Reunion – Mascarene Islands	International	Data47.dat
58	Romania – S-42 (Pulkovo 1942)	Krassovsky 1940	Data69.dat
59	Rome 1940 – Italy	International	Data49.dat
60	Saudi Arabia – Ain el Abd 1970	International	Data50.dat
61	Singapore	Modified Fischer 1960	Data51.dat
62	South Africa	Clarke 1880	Data52.dat
63	Thailand 1975	Everest 1830	Data54.dat
64	Tokyo_Japan	Bessel 1841	Data60.dat
65	Tokyo_Korea	Bessel 1841	Data61.dat
66	Tokyo_Mean	Bessel 1841	Data59.dat
67	Tokyo_Okinawa	Bessel 1841	Data62.dat
68	Trinidad, Tobago	South American 1969	Data55.dat
69	Venezuela	South American 1969	Data57.dat
70	Venezuela – Provisional American 1956	International	Data56.dat
71	WGS84	WGS84	Data58.dat

6.2 Setting Syntax

6.2.1 Manufacturing Default:

Datum: WGS84.
 Baud Rate: 4800.
 Output: GGA, GSA, GSV, RMC.

6.2.2 Datum change syntax:

```
>DOS\Sirfprog /Fdataxx.dat -Px -Bx -Csh1
```

-Px: x is com port, 1= COM1, 2 = COM2
 -Bx: Baud rate, 4800, 9600, 19200 or 38400

Example:
 Change Datum to WGS84,
 Sirfprog /Fdata58.dat -P1 -B4800 -Csh1 <Entry>

After changing datum, the new datum will be kept in SRAM. If no power supplied to GR-213 for more than 30 days, user must re-set datum when power on.

7. Ordering Information

7.1 Product Options

Explanation of product Number

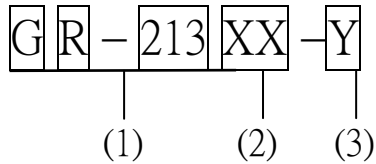

- (1) Model name:GR-213
- (2) XX: Color option
- (3) Y: Output Type option
 - 1: RS232+TTL
 - 2: RS232 + DGPS

Model	Output level	Option Accessories type ⁽¹⁾
GR-213-XX-1	RS-232+TTL	1,2,3,4
GR-213-XX-2	RS-232+DGPS	1,3,4

(1) Option Accessories type reference section 7.2

7.2 Accessories type

Type	Name	Function description
1	CA-RS232	Convertible cable, Comport, 5VDC input.
2	CA-USB	USB connector
3	CA-6V30V	High power connector, 6-30VDC
4	A-20005	12V-26V Cigarette Adapter /Charger

8. Warranty

The GR-213 is warranted to be free from defects in material and functions for one year from the date of purchase. Any failure of this product within this period under normal conditions will be replaced at no charge to the customers.